

Innovation in power conversion



Product Selector Guide

Metering Products

February 2011

C6
47 μ F
35 V

D7
1148

1F
/



Product Selector Guide

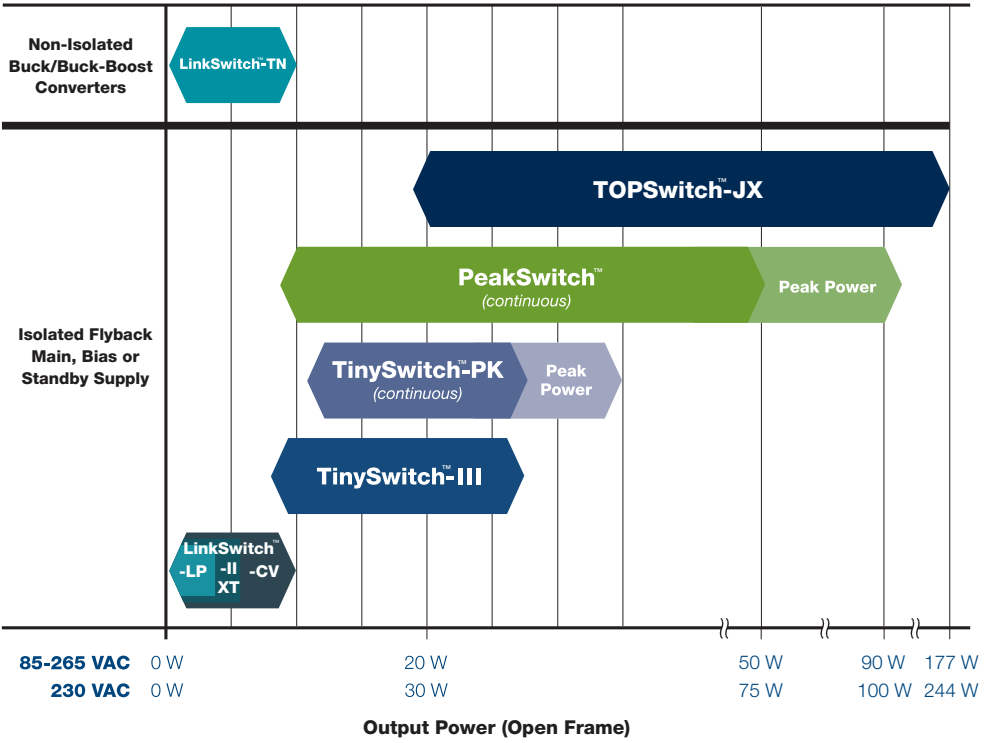

Output Characteristic Requirements (Wide Input 85 – 265 VAC)

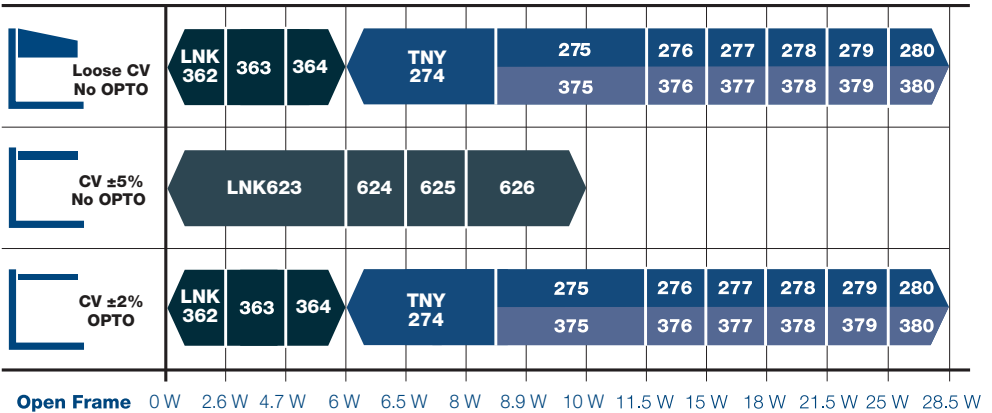
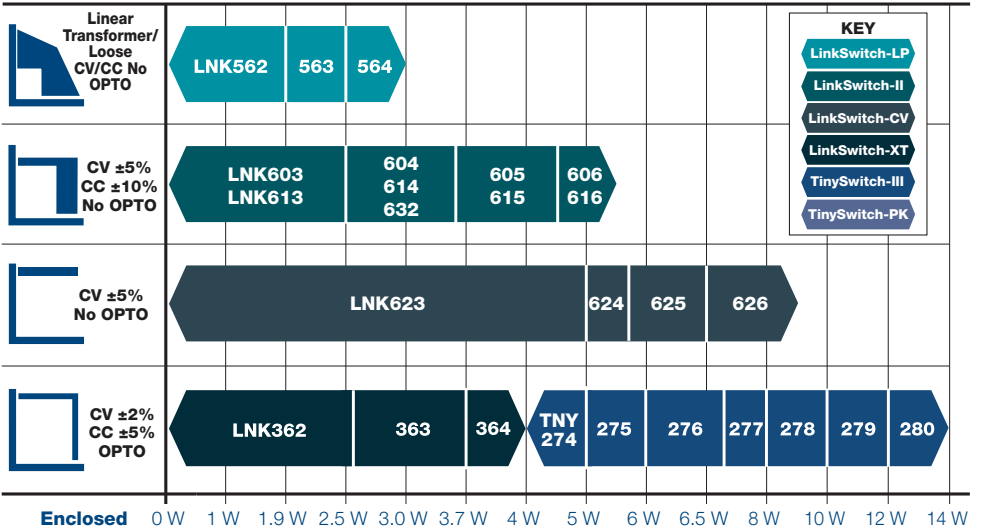

IC Product Tables and Design Examples

Very Low Power AC-DC, Non-Isolated Linear/Passive Supply Replacement (≤ 360 mA)

Product ⁴	Output Current ¹ (mA)		Output Current ¹ (mA)	
	MDCM ²	CCM ³	MDCM ²	CCM ³
LinkSwitch-TN	230 VAC \pm 15%		85-265 VAC	
LNK302P/G/D	63	80	63	80
LNK304P/G/D	120	170	120	170
LNK305P/G/D	175	280	175	280
LNK306P/G/D	225	360	225	360

Additional Features:

- 700 V internal MOSFET rating
- Self-powered
- ON/OFF control
- Hysteretic thermal shutdown
- Power limiting
- Frequency jitter reduces EMI
- EcoSmart™ low standby/no-load power consumption

Notes:

1. Typical output current in a non-isolated buck converter. Output power capability depends on respective output voltage.
2. Mostly discontinuous conduction mode.
3. Continuous conduction mode.
4. Packages: P: DIP-8B, G: SMD-8B, D: SO-8C.

Very Low Power AC-DC Power Conversion (Up to 17 W)

Product ^{3,4}	Continuous Output Power (W)		Continuous Output Power (W)	
	Adapter ¹	Open Frame ²	Adapter ¹	Open Frame ²
LinkSwitch-CV	230 VAC \pm 15%		85-265 VAC	
LNK623P/D	6.5	9	5.0	6
LNK624P/D	7	11	5.5	6.5
LNK625P/D	8	13.5	6.5	8
LNK626P/D	10.5	17	8.5	10
LinkSwitch-II	230 VAC \pm 15%		85-265 VAC	
LNK603/613P/D	2.5	3.3	2.5	3.3
LNK604/614P/D	3.5	4.1	3.5	4.1
LNK605/615P/D	4.5	5.1	4.5	5.1
LNK606/616P/G/D	5.5	6.1	5.5	6.1
LNK632D	3.1	3.1	3.1	3.1
LinkSwitch-LP	230 VAC \pm 15%		85-265 VAC	
LNK562P/G/D	1.9	1.9	1.9	1.9
LNK563P/G/D	2.5	2.5	2.5	2.5
LNK564P/G/D	3	3	3	3
LinkSwitch-XT	230 VAC \pm 15%		85-265 VAC	
LNK362P/G/D	2.8	2.8	2.6	2.6
LNK363P/G/D	5	7.5	3.7	4.7
LNK364P/G/D	5.5	9	4	6

Additional Features:

- 700 V internal MOSFET rating
- Self-powered
- ON/OFF control
- Hysteretic overtemperature protection
- Power limiting
- Frequency jitter reduces EMI
- EcoSmart low standby/no-load power consumption

Notes:

1. Minimum continuous power in a typical non-ventilated enclosed adapter measured at 50 °C ambient.
2. Minimum practical continuous power in an open frame design with adequate heat sinking, measured at 50 °C ambient.
3. Packages: P: DIP-8B, G: SMD-8B, D: SO-8C.
4. Packages: P: DIP-8C, G: SMD-8C, D: SO-8C.

Low Power AC-DC Power Conversion (Up to 36.5 W)

Product ³	Continuous Output Power (W)		Continuous Output Power (W)	
	Adapter ¹	Open Frame ²	Adapter ¹	Open Frame ²
TinySwitch-III	230 VAC \pm 15%		85-265 VAC	
TNY274P/G	6	11	5	8.5
TNY275P/G	8.5	15	6	11.5
TNY276P/G	10	19	7	15
TNY277P/G	13	23.5	8	18
TNY278P/G	16	28	10	21.5
TNY279P/G	18	32	12	25
TNY280P/G	20	36.5	14	28.5

Notes:

1. Minimum continuous power in a typical non-ventilated enclosed adapter with minimal heat sinking, measured at a device ambient of 50 °C.
2. Minimum continuous power in an open frame design with adequate heat sinking. TinySwitch-III operates without bias winding.
3. Packages: P: DIP-8C, G: SMD-8C.

Additional Features:

- 700 V internal MOSFET rating
- Self-powered
- Hysteretic overtemperature protection
- Frequency jitter reduces EMI
- EcoSmart low standby/no-load power consumption
- On-time extension
- Latching output overvoltage protection
- Line undervoltage lockout
- Selectable current limit

TinySwitch-PK (Up to 36.5 W Continuous, 45 W Peak)

Product ³	Continuous Output Power (W)			Continuous Output Power (W)		
	Adapter ¹	Open Frame ²	Peak	Adapter ¹	Open Frame ²	Peak
TinySwitch-PK	230 VAC \pm 15%			85-265 VAC		
TNY375 P/G/D ⁴	8.5	15	16.5	6	11.5	12.5
TNY376 P/G/D ⁴	10	19	22	7	15	17
TNY377 P/G	13	23.5	28	8	18	23
TNY378 P/G	16	28	34	10	21.5	27
TNY379 P/G	18	32	39	12	25	31
TNY380 P/G	20	36.5	45	14	28.5	35

Additional Features:

- 700 V Internal MOSFET rating
- ON/OFF control
- Hysteretic overtemperature protection
- Frequency jitter reduces EMI
- EcoSmart low standby/no-load power consumption
- On-time extension
- Latching shutdown
- Latching output overvoltage protection
- Selectable current limit

Notes:

1. Minimum continuous power in a typical non-ventilated enclosed adapter measured at 50 °C. Use of an external heat sink will increase power capability.
2. Minimum continuous power in an open frame design (see Key Applications Considerations in data sheet).
3. Package: P: DIP-8C, G: SMD-8C, D: SO-8C.
4. See Key Application Considerations in data sheet.

Super Peak AC-DC Power Conversion (Up to 75 W Continuous, 126 W Peak)

Product ³	Continuous Output Power (W)		Continuous Output Power (W)	
	Adapter ¹	Adapter Peak ²	Adapter ¹	Adapter Peak ²
PeakSwitch	230 VAC ± 15%		85-265 VAC	
PKS603P	13	32	9	25
PKS604P	23	56	16	44
PKS604Y/F	35	56	23	44
PKS605P	31	60	21	44
PKS605Y/F	46	79	30	58
PKS606P	35	66	25	46
PKS606Y/F	68	117	45	86
PKS607Y/F	75	126	50	93

Notes:

- Typical continuous power in a non-ventilated enclosed adapter measured at +50 °C ambient.
- Typical peak power for a period of 100 ms and a duty cycle of 10% in a non-ventilated enclosed adapter measured at +50 °C (see Key Application Considerations section in data sheet for details).
- Packages: PN: DIP-8C, YN: TO-220-7C, FN: TO-262-7C.

Additional Features:

- 700 V internal MOSFET rating
- ON/OFF control
- Hysteretic thermal shutdown
- Frequency jitter reduces EMI
- EcoSmart low standby/no-load power consumption
- Adaptive on-time extension
- Adaptive current limit
- Fast AC reset
- Smart AC sense with latching OVP shutdown

High Efficiency AC-DC Power Conversion (Up to 244 W)

Product ⁵	PCB Copper Area ¹			
	Adapter ² (W)	Open Frame ³ (W)	Adapter ² (W)	Open Frame ³ (W)
TOPSwitch-JX	230 VAC ± 15%*		85-265 VAC	
TOP264V	21	34	12	22.5
TOP264K	30	49	16	30
TOP265V	22.5	36	15	25
TOP265K	33	53	20	34
TOP266V	24	39	17	28.5
TOP266K	36	58	23	39
TOP267V	27.5	44	19	32
TOP267K	40	65	26	45
TOP268V	30	48	21.5	36
TOP268K	46	73	30	50
TOP269V	32	51	22.5	37.5
TOP269K	50	81	33	55
TOP270V	34	55	24.5	41
TOP270K	56	91	36	60
TOP271V	36	59	26	43
TOP271K	63	102	40	66

Product ⁵	Metal Heat Sink ¹			
	Adapter ² (W)	Open Frame ³ (W)	Adapter ² (W)	Open Frame ³ (W)
TOPSwitch-JX	230 VAC ±15%*		85-265 VAC	
TOP264E/V	30	62	20	43
TOP265E/V	40	81	26	57
TOP266E/V	60	119	40	86
TOP267E/V	85	137	55	103
TOP268E/V	105	148	70	112
TOP269E/V	128	162	80	120
TOP270E/V	147	190	93	140
TOP271E/V	177	244	118	177

Additional Features:

- Multi-mode operation maximizes efficiency at all loads
- New eDIP™-12 package
 - Low profile horizontal orientation for ultra-slim designs
 - Heat transfer to both PCB and heat sink
 - Optional external heat sink provides thermal impedance equivalent to a TO-220
- Output overvoltage protection is user programmable for latching/non-latching shutdown with fast AC reset
 - Allows both primary and secondary sensing
- Line undervoltage detection prevents turn-off glitches
- Line overvoltage shutdown extends line surge limit
- Accurate programmable current limit
- Optimized line feed-forward for line ripple rejection
- 132 kHz frequency reduces transformer and power supply size
 - Half frequency option for video applications
- Frequency jittering reduces EMI filter cost
- Improved auto-restart delivers <3% of maximum power in short circuit and open loop fault conditions
- Accurate hysteretic thermal shutdown function automatically recovers
- Fully integrated soft-start for minimum start-up stress

Notes:

- See Key Application Considerations section for more details.
- Minimum continuous power in a typical non-ventilated enclosed adapter measured at +50 °C ambient temperature.
- Minimum continuous power in an open frame design at +50 °C ambient temperature.
- 230 VAC or 110V/115 VAC with doubler.
- Packages: E: eSIP-7C, V: eDIP-12, K: eSOP™-12.

LinkSwitch-TN – Non-Isolated Dual Output Buck (RDK-138)

1.2 W, DUAL OUTPUT, NON-ISOLATED, 85 – 265 VAC INPUT BUCK CONVERTER

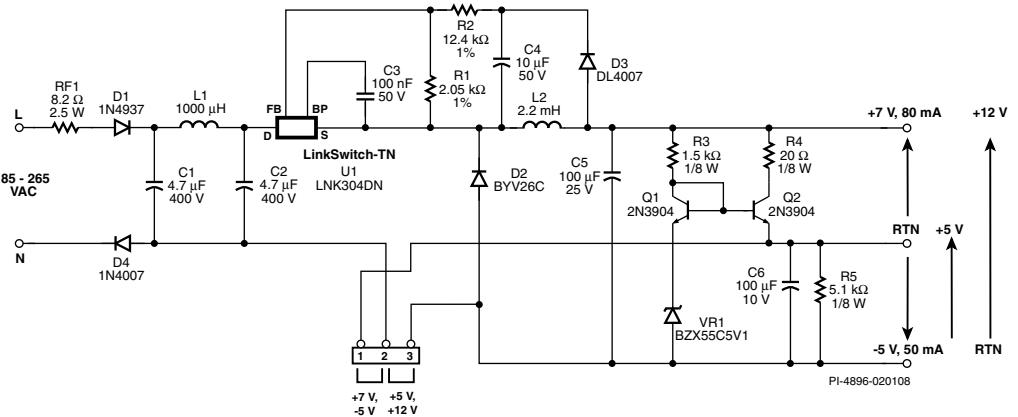

LinkSwitch-TN – Ultra Wide Input Range Power Supply (DI-124)

3 W, 12 V, 250 mA OUTPUT, 57 – 580 VAC INPUT FLYBACK CONVERTER

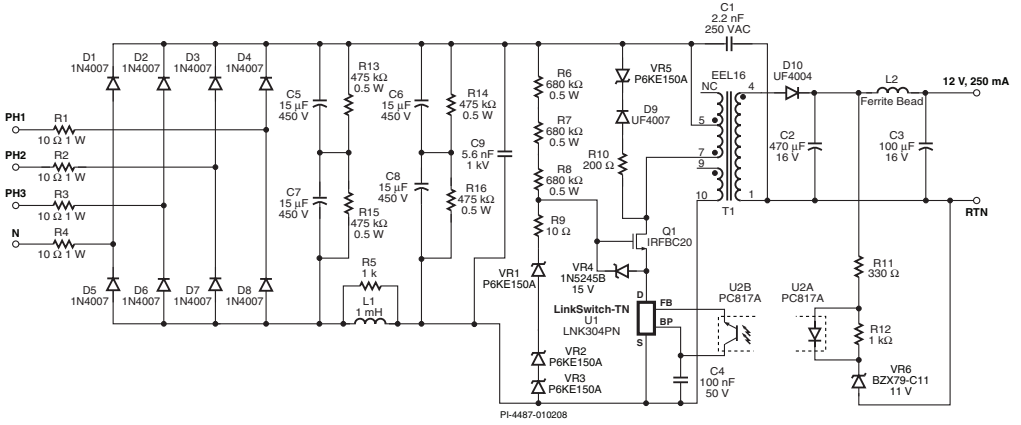

LinkSwitch-II – Low Power Constant Voltage, Constant Current Charger/Adapter (RDR-158)

5 V, 5 V, 1 A OUTPUT, 85 – 265 VAC INPUT FLYBACK POWER SUPPLY

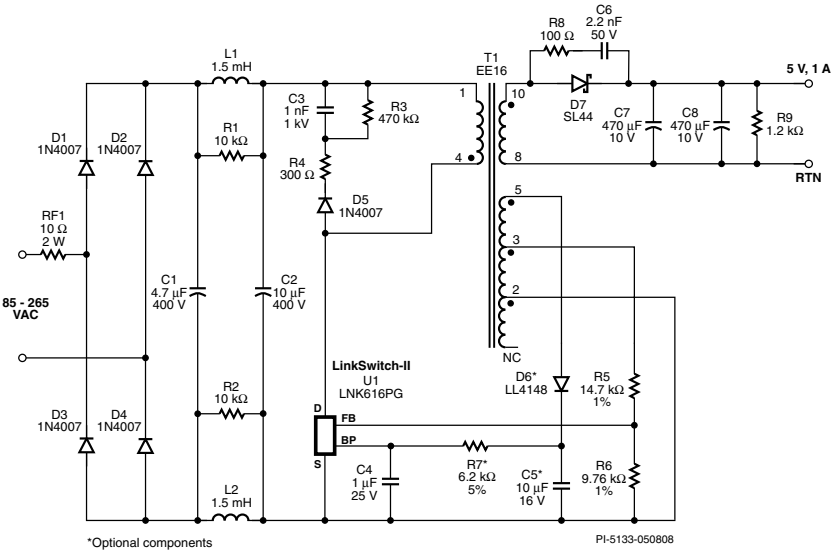

*Optional components

LinkSwitch-LP – Low Cost Linear Replacement (DI-164)

1 W, 7 V, 14 A OUTPUT, 85 – 265 VAC INPUT FLYBACK CONVERTER WITHOUT ELECTROLYTIC INPUT CAPACITOR

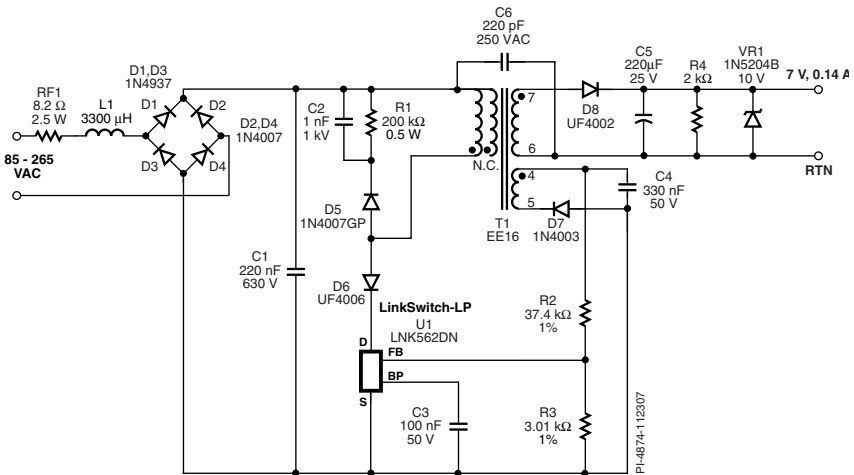

LinkSwitch-XT – Tamper Proof Energy Meter Power Supply (DER-141)

0.75 W, 5 V, 150 mA OUTPUT, 85 – 265 VAC INPUT FLYBACK CONVERTER

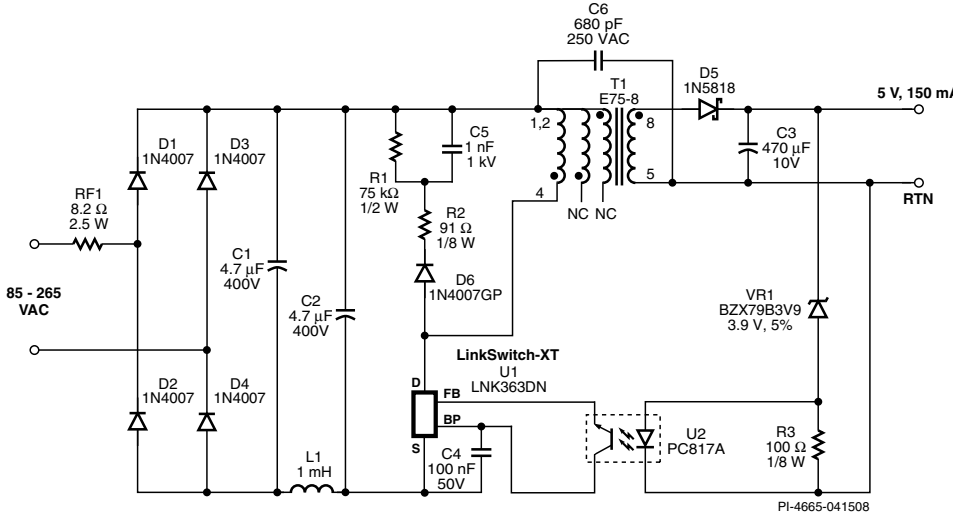

LinkSwitch-CV – 2-Output Constant Voltage Power Supply (DER-213)

3.8 W, 5 V, 0.15 A, 12 V, 0.25 A, 85 – 265 VAC INPUT FLYBACK POWER SUPPLY

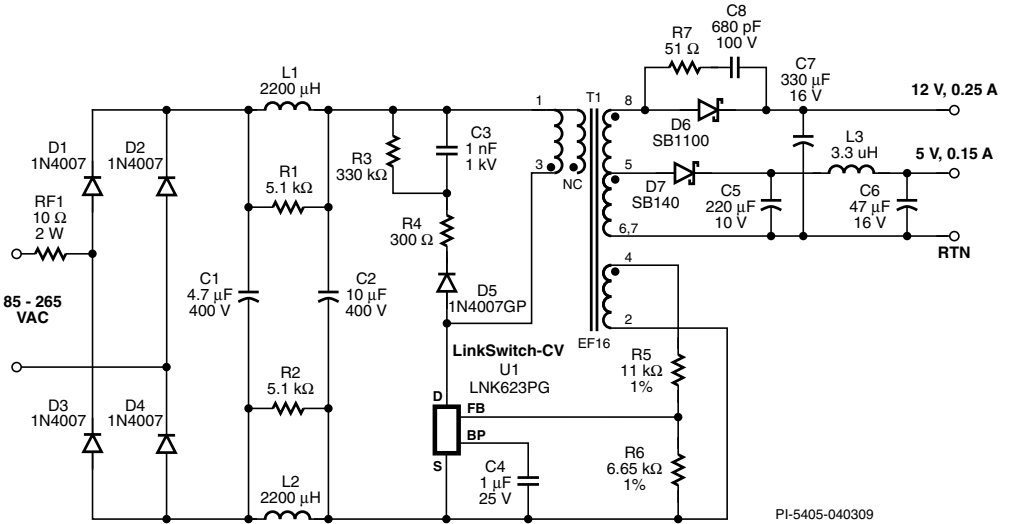

TinySwitch-III – Universal Input Adapter (RDK-91)

12 W, 12 V, 1 A OUTPUT, 85 – 265 VAC INPUT FLYBACK CONVERTER

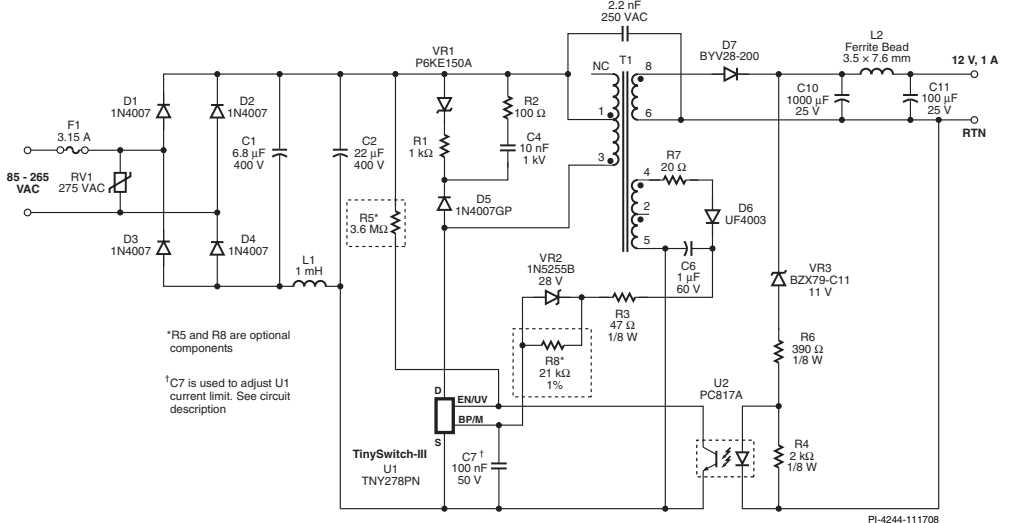

World Headquarters 5245 Hellyer Avenue, San Jose, CA 95138, USA, Main: +1-408-414-9200
 Customer Service Phone: +1-408-414-9665, Fax: +1-408-414-9765, Email: info@powerint.com

On the Web www.powerint.com

©2011 Power Integrations. Power Integrations, TOPSwitch, TinySwitch, LinkSwitch, DPA-Switch, PeakSwitch, CAPZero, SENZero, LinkZero, HiperPFS, HiperTFS, Qspeed, EcoSmart, Clampless, E-Shield, Filterfuse, StakFET, PI Expert and PI FACTS and the Power Integrations logo are trademarks or registered trademarks of Power Integrations, Inc. All rights reserved.

